

Full Length Research Paper

Performance evaluation of a v-groove solar air collector for drying maize (*Zea mays*) in Iraq

Mudafer kareem Abdullah and Ahmed Abed Gatea*

Department of Agricultural mechanization, College of Agriculture, University of Baghdad, Baghdad, Iraq.

Accepted 21 January, 2020

In this work, a solar drying system was constructed, consisting of three parts (solar collector, drying chamber, and air blower). Solar collector having V-corrugated absorption plate of two air passes, a single glass cover was used. The total area of the collectors is 2.04 m². The dimension of the drying chamber is 1.06, 0.66 and 0.56 m for width, depth, and height, respectively. 38 kg of corn were dried. The moisture content was reduced from 21 to 13% within four hours drying. The drying air temperatures at the inlet of the dryer were found in the range of 30 to 45°C when the range of ambient air temperature was from 8.5 to 20°C and total solar radiation intensity was from 270 to 560 W/m². Increasing volumetric air flow rate from 0.025 to 0.030 m³/s raises the daily solar collector efficiency by 3.25%, while increasing volumetric air flow rate from 0.030 to 0.035 m³/s raises the solar daily collector efficiency by 11.11%. The drying rate is reduced with the decrease of moisture content. Efficiency of the collector is very much dependant on air flow rate.

Key words: Solar energy, solar air collector, two passes collector, V-corrugated collector, solar drying, performance evaluation.

INTRODUCTION

Maize (*Zea mays*) falls into the cereal group of food crops, used for food by both human being and animals. At harvest, maize usually contains too much moisture (about 20 to 25%) which is a favorable environment for the growth of moulds (fungi) and insects that normally cause grain damage. In order to avoid this, drying of the maize must be done to reduce the moisture content to about 11.8 to 13% for safe year-round storage. In many parts of the world, there is a growing awareness that renewable energy have an important role to play in extending technology to the farmer in developing countries to increase their productivity (Jompob, 2006). That is rapidly gaining acceptance as an energy saving measure in agriculture application. It is preferred to other alternative sources of energy such as wind and shale, because it is abundant, inexhaustible, and non-polluting (Akinola, 1999; Akinola and Fapetu, 2006; Akinola et al., 2006). They are defined as a process of moisture removal due to simultaneous heat and mass transfer (Ertekin and Yaldiz, 2004). According to Ikejiofor (1985),

two types of water are present in food items, the chemically bound water and the physically held water. Solar air heaters are simple devices to heat air by utilizing solar energy and employed in many applications requiring low to moderate temperature below 80°C, such as crop drying and space heating (Kurtbas and Turgut, 2006).

ANALYSIS

Instantaneous thermal efficiency of a collector is defined as the ratio of the useful thermal energy gained to the total incident solar energy, averaged over the same time interval. Mathematically, efficiency of a collector is expressed as Equation (1) (Duffie, 1991):

$$\eta_i = \frac{\dot{m}C_p \int_{t_1}^{t_2} (T_o - T_i) dt}{A_c \int_{t_1}^{t_2} I_T dt} \quad (1)$$

The quantities (\dot{m} and C_p) have been taken out of the integration because these can be considered constant during the time interval of measurements. The steady

*Corresponding author. E-mail: ahmedabd192000@yahoo.com.
Tel: 07801870847.

state efficiency of the solar air collector is given by Equation (2), known as Hottel–Whillier–Bliss (Duffie, 1991):

$$\eta_c = \frac{Q_u}{I_T \times A_c} \quad (2)$$

The theoretical useful energy gain can be determined by the following:

$$Q_{ut} = A_c F_R \left[I_T (\tau \times \alpha') - U_L (T_i - T_a) \right] \quad (3)$$

where () collector effective absorptance can be determined from the following Equation (4) (Joudi and Mohammed, 1986)

$$\alpha' = \frac{\bar{\alpha}}{1 - (1 - \alpha') (1 - \sin \phi)} \quad (4)$$

where (FR) heat removal factor defined as the ratio of actual heat transfer to the maximum possible heat transfer and can be expressed as Equation (5) (Duffie, 1991)

$$F_R = \frac{GC_p}{U_L} \left[1 - e \left(\frac{-F' U_L}{GC_p} \right) \right] \quad (5)$$

where collector efficiency factor (F'), a measure of the effectiveness of the collector in transferring heat to the transport fluid (dimensionless) and can be determined from the following Equation (6) (Duffie, 1991):

$$F' = \frac{h_c}{h_c + U_L \sin \left(\frac{\phi}{2} \right)} \quad (6)$$

where: h_c is the forced heat transfer coefficient and can be determined from the following Equation (7):

$$h_c = \frac{Nu_a C_{p,f}}{P_r D_h} \quad (7)$$

Nu is Nusselt number and can be determined from the following Equation (8) (Kreith and Kreider, 1981):

$$Nu = \frac{0.0192 Re^{0.75} Pr}{1 + 1.22 Re^{-0.125} Pr^{-2}} \quad (8)$$

Re is the Reynolds number and can be determined from

the following Equation (9):

$$Re = \frac{\rho \bar{v} D_h}{\mu} \quad (9)$$

Where (\bar{v}) average velocity of air (m/s).

From the following Equation (10)

$$\bar{v} = \frac{m \dot{v} \times A_c}{A_d \dot{m} t} \quad (10)$$

The actual heat gain from the experimental measurement is determined from the following Equation (11):

$$Q_{ut} = m c_p (T_{oc} - T_{ic}) \quad (11)$$

An empirical equation, derived by Klein (year???) (Garg and Datta), is used in the computation of top loss coefficient, U_t , and is given by Equation (12)

$$U_t = \left[\frac{N}{\left(\frac{C}{T_p} \right) \left[\frac{(T_p - T_a)}{(N+f)} \right]^e + \frac{1}{h_w}} \right]^{-1} + \frac{\delta (T_p^2 - T_a^2) (T_p + T_a)}{\frac{1}{d} + \frac{2N + f - 1}{\varepsilon_g} - N} \quad (12)$$

Where

$$C = \frac{204.429 (\cos \beta)^{0.252}}{L^{0.24}}$$

$$d = \varepsilon_p + 0.0425 N (1 - \varepsilon_p)$$

$$f = \left(\frac{9}{h_w} - \frac{30}{h_w^2} \right) \left(\frac{T_a}{316.9} \right) (1 + 0.091 N)$$

$$h_w = 5.7 + 3.8 v$$

$$e = 0.252$$

Thermal loss coefficient from the bottom could be calculated as following Equation (13)

$$U_b = \frac{k_{ins}}{L_{ins}} \quad (13)$$

The total heat loss coefficient is given by Equation (14):

$$U_L = U_t + U_b \quad (14)$$

The configuration of a v-groove air collector is shown in Figure 1.

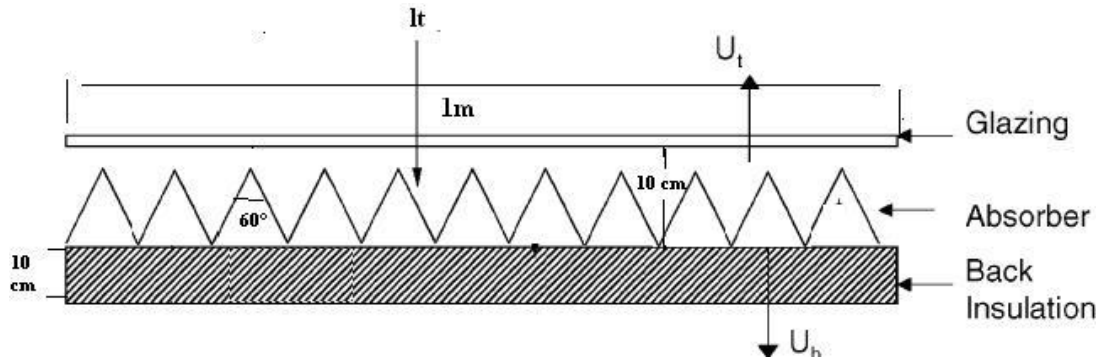

Figure 1. v-groove air collector.

The quantity of air needed for drying

Given the airflow rate, psychometric calculations using the procedure described by Exell (1980) show that drying will take place even when the temperature rise is low. Preliminary calculations assumed that hay was to be dried at 38 kg of maize. After field drying, the moisture content of the hay was 21% (wet basis) and this is to be reduced to 13% during drying. The relevant equation is to determine M_w . The quantity of water is calculated from the initial and desired final moisture content using the following Equation (15):

$$M_w = \frac{M_c[W_I - W_F]}{100 - W_F} \quad (15)$$

where W_I is the initial moisture content, W_F is the final moisture content, and M_C is the initial mass of the crop. Both W_I and W_F are taken on a wet basis. According to the Equation (15), the mass of moisture evaporated:

$$M_w = 38 \text{ kg} \left\{ \frac{21 - 13}{(100 - 13)} \right\} = 38 \frac{12}{87} = 5.24 \text{ Kg}$$

If one assumes that each kg of water requires 2.5 MJ of heat for its removal, then the total heat removed is:

$$2.5 \frac{\text{MJ}}{\text{kg}} * 5.24 \text{ kg} = 13.1 \text{ MJ}$$

Exell (1980) gives a procedure for calculating the amount of water which can be removed by the airstreams; this is then employed using a psychometric chart. Figure 2 Assuming an input air temperature of 25°C (dry bulb) and a relative humidity of 70%, the psychometric chart shows that its humidity ratio is 0.0141 kg water/kg dry air. When

the solar collector heats it to, say, 40°C (dry bulb), the humidity ratio remains constant. If on passing through the crop, the air absorbs moisture until its relative humidity is 90%. The psychometric chart shows the humidity ratio to be 0.020 kg water/kg dry air. The change in humidity ratio is therefore: 0.020 - 0.0141 = 0.0059 and the corresponding dry bulb temperature is 28.2°C.

From the gas laws equation (16):

$$PV = M_A R T \quad (16)$$

where P is the atmospheric pressure = 101.3 KPa, V = the volume of air in m³. M_A = the mass of the air in kg, T = the absolute temperature in Kelvin, and R = the gas constant = 0.291 kPa m³/kg K.

For a humidity ratio increase of 0.0059 kg water/ kg dry air, each kg of water will require 1/0.0059 = 169.5 kg dry air. For this calculation, the absolute temperature is 28.2 + 273 = 301.2 K and the volume of air needed to remove 1 kg of water is:

$$169.5 * 0.291 * \frac{301.2}{101.3} = 146.6 \text{ m}^3$$

Hence 5.24 will require 5.24 × 146.6 = 768.18 m³.

For a drying time of 6 h operating time per day, which equal to 6 × 3600 = 21600 s.

The air flow rate is therefore:

$$768.18 \text{ m}^3 / 21600 \text{ sec} = 0.0356 \text{ m}^3 / \text{sec}$$

Collector design

The detail configuration of the collector considered in this study is shown in Figure 3. The collector was designed to

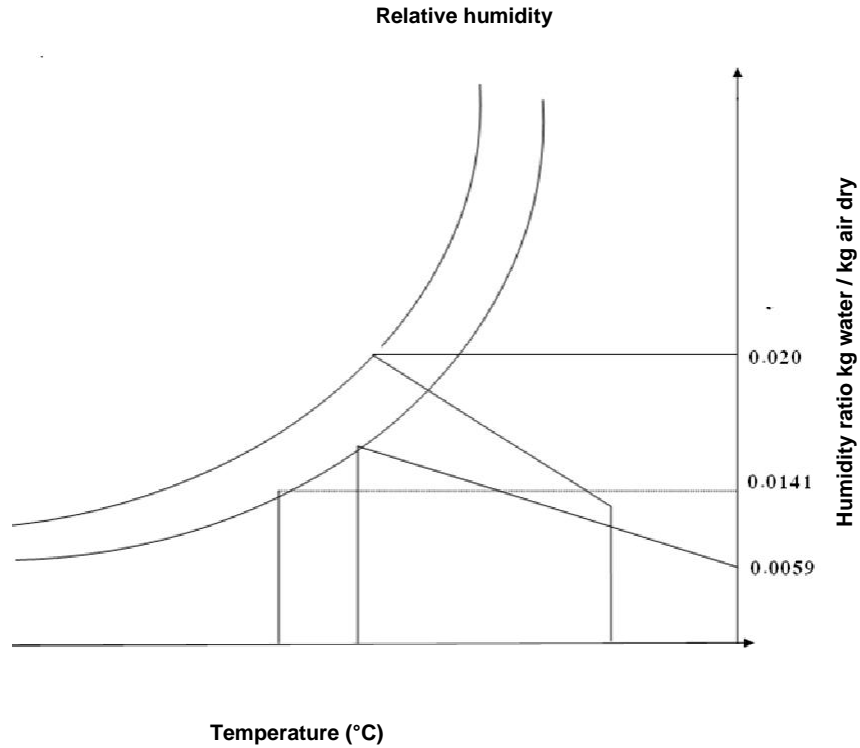

Figure 2. Schematic representation on a psychrometric chart of the air evolution in a solar drier.

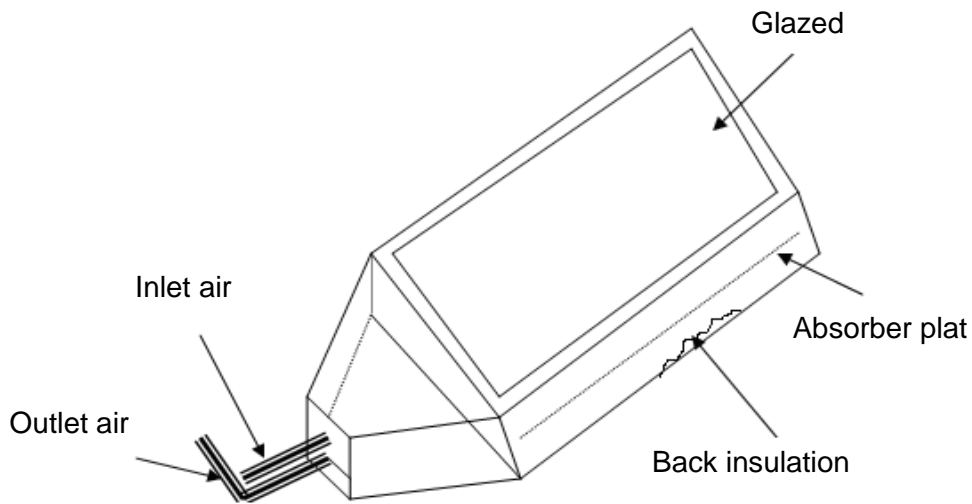

Figure 3. Isometric view of the solar collector.

perform testing with two passes of air flowing through the plate. Detail specification of the test collector is given as:

1. Absorber material: Black-painted galvanized steel.
2. Plate type: v-corrugated (60°)
3. Dimension of absorber plate: 2.04 × 1 m
4. Absorber plate thickness: 1 mm

5. Glazing: Normal window glass (thickness 4 mm)
6. No. of glazing: 1
7. The collector was insulated with rock wool of 10 mm thick from the bottom and 5 mm thick from the sides.
8. The collector was contained within galvanized steel frame.
9. Collector tilt angle 45° from the horizontal.

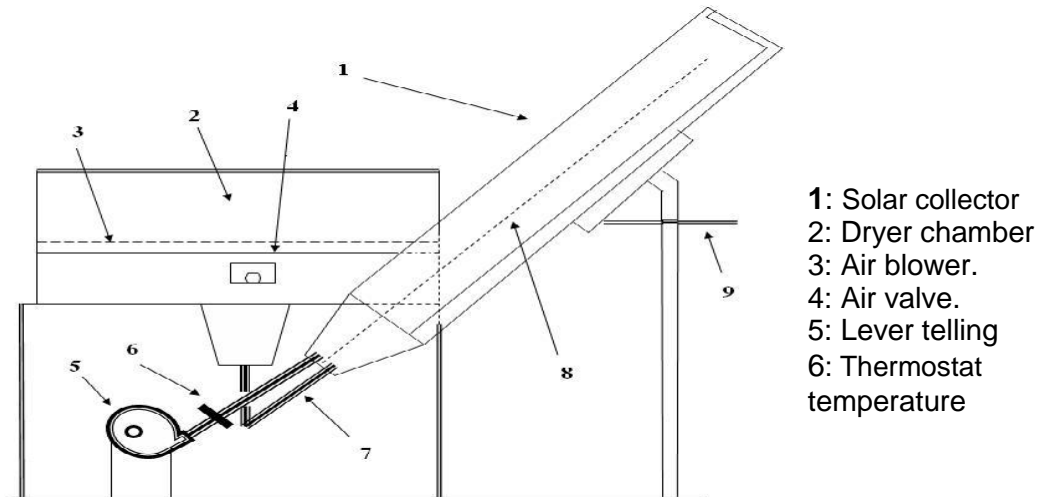

Figure 4. Illustrate the solar drying.

- 1: Solar collector
- 2: Dryer chamber
- 3: Air blower.
- 4: Air valve.
- 5: Lever telling
- 6: Thermostat temperature

The area of absorber plate required

The area of absorber required to collect sufficient solar energy to dry quantity of maize can be determined, provided we know the mass of water to be evaporated, the specific latent heat of vaporization of the water, the quantity of global solar radiation falling on the unit per day and the efficiency of the drying unit. The amount of heat required to evaporate the water is calculated from the following Equation (16):

$$Q_R = I_T (\tau\alpha') t A_c \eta_c \quad (16)$$

where is effective transmittance-absorbance product of cover and absorber combination.

The drying chamber design

The drying chamber used in this work was 1.06, 0.66 and 0.56 m for width, depth, and height with clasped shelf where 38 kg of maize were put. The hot air was transported from the output of the collector to the input of the drying chamber by plastic pipes of 60 mm diameter. Figure 4

The experiments

Experimental procedure describes the ability of the collector air heater in the product dry systems. The experiments were done at different working conditions as: Set of experiments at three flow rates (0.025, 0.03 and 0.035 m³/s) in the experiments. The standards

(ANSI/ASAE S423 DEC1991 (R2007)) were used. The experiments were done in the energy and environment research center/ ministry of industry and minerals.

Measuring equipments

Solar irradiation measurement

Total solar irradiation was measured using a pyranometer (Solar meter mod 776); the solar radiation on the collector was measured at 15 min interval, according to standard.

Temperature measurement

Temperature at any point was measured using 12 suitable calibrated copper-constantan thermocouples connected to a digital thermometer (Cole- Parmer Instrument Company) through a selective switch to measure the temperature of all the selected points in the system with accuracy of $\pm 1\%$.

Air-flow rate measurement

The velocity of the air in the pipes was measured by using (TA 6000) anemometer. The range of the velocities of this instrument is (0.1 to 25 m/s).

RH measurement

The air relative humidity is measured using hygrometer with measuring range of 10 to 95% and accuracy of ($\pm 5\%$).

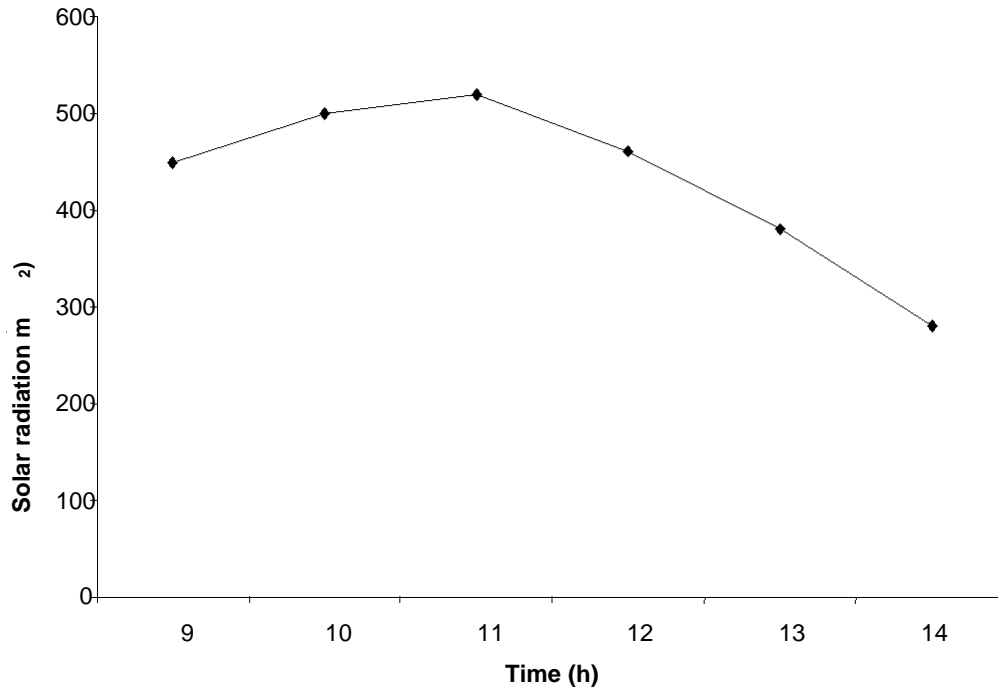

Figure 5. Variation of average solar radiation with solar time.

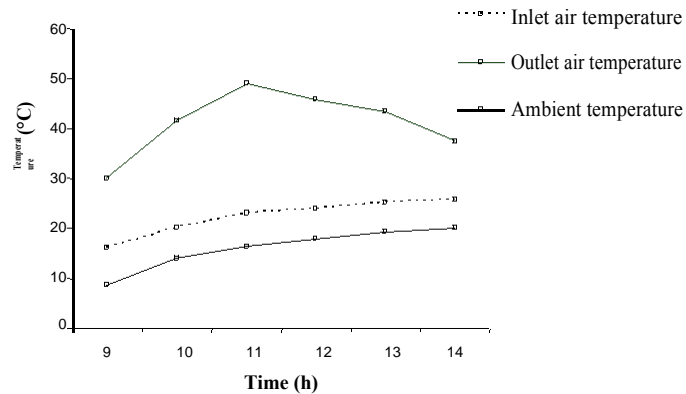

Figure 6. Variations in ambient temperature, inlet air temperature and outlet air temperature with time in a day for a typical experimental run during solar drying of maize.

Moisture content of maize

The moisture content of the dried maize was determined using the device measuring moisture content mode German type (HOH-Express (HE-50)).

RESULTS AND DISCUSSION

Performance of the solar dryer

The performance of the solar dryer was highly dependent on the solar radiation (Figure 5), ambient temperature

and the temperature difference between inlet and outlet air which was low in the morning and evening periods as compared to the afternoon where temperature difference was high as shown in Figure 6. The drying air gained temperature with a minimum of 30°C to a maximum of 49°C at the corresponding air flow rate of 0.025 m³/s.

Effect of the air flow rate

Figure 7 shows graphic comparison of drying air temperature for three volumetric air flow rates of (0.025, 0.03 and 0.035 m³/s). It is clear from the figure that the

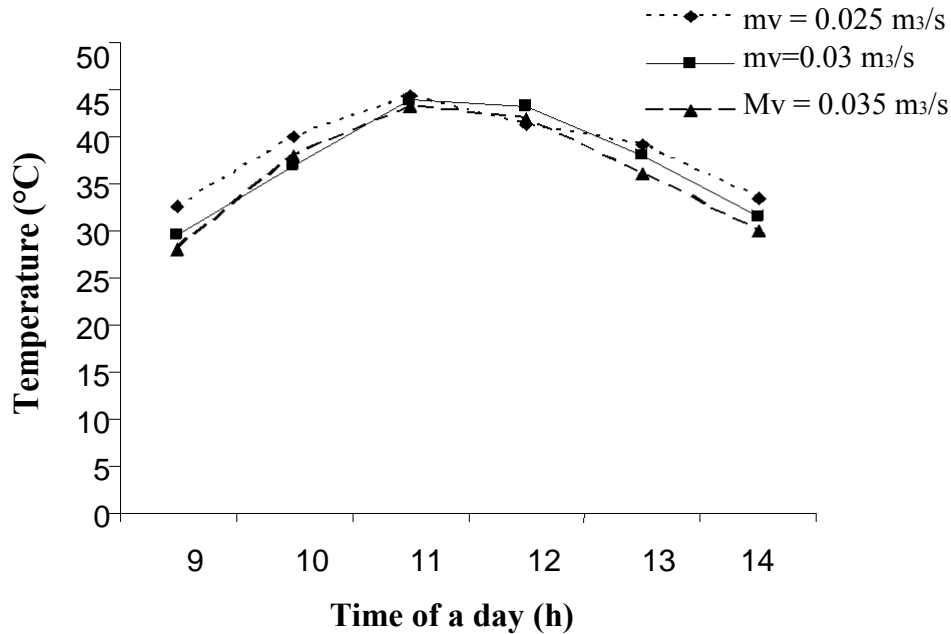

Figure 7. Comparison of drying air temperature for difference air flow rates.

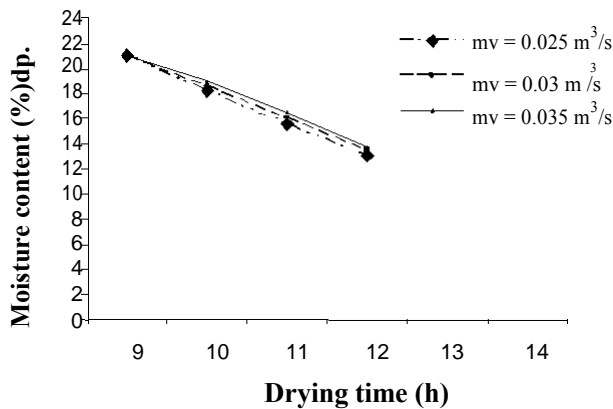

Figure 8. The comparison of moisture content of solar dryer at difference air flow rates.

drying air temperatures are substantially higher at the lowest volumetric air flow rate.

Percentage moisture drying

The moisture content was reduced from 21.1 to 13% on dry basis during four hours of drying. It was observed that the drying rate increased due to increase in temperature between 10.00 and 12.00 h (Figure 8) because for higher temperatures required for drying of the lower volumetric flow rate of $0.025 \text{ m}^3/\text{s}$.

Daily collector efficiency

The collector efficiency was found to increase with increasing mass flow rate. This is due to the increase of the convective heat transfer coefficient and the associated decrease of the collector losses. At the lower flow rate ($0.025 \text{ m}^3/\text{s}$), the collector efficiency was found to be 38.7% at $0.03 \text{ m}^3/\text{s}$, the collector efficiency was found to be 40% and at $0.035 \text{ m}^3/\text{s}$, the collector efficiency was found to be 45% (Figure 9).

Conclusion

On the basis of the results, the following conclusion can be drawn:

1. The drying air temperature at the inlet of the drying chamber was found to be in the range from 30 to 45°C.
2. 38 kg was dried from 21 to 13% during four hours.
3. Efficiency of the collector is very much dependant on air mass flow rate. Increasing volumetric air flow rate from 0.025 to $0.030 \text{ m}^3/\text{s}$ raises the solar collector efficiency by 3.25%, while increasing volumetric air flow rate from 0.030 to $0.035 \text{ m}^3/\text{s}$ raises the solar collector efficiency by 11.11%.
4. The moisture content of the dried maize decreases with increase in the time for a given temperature.
5. The drying rate is reduced with the decrease of moisture content.

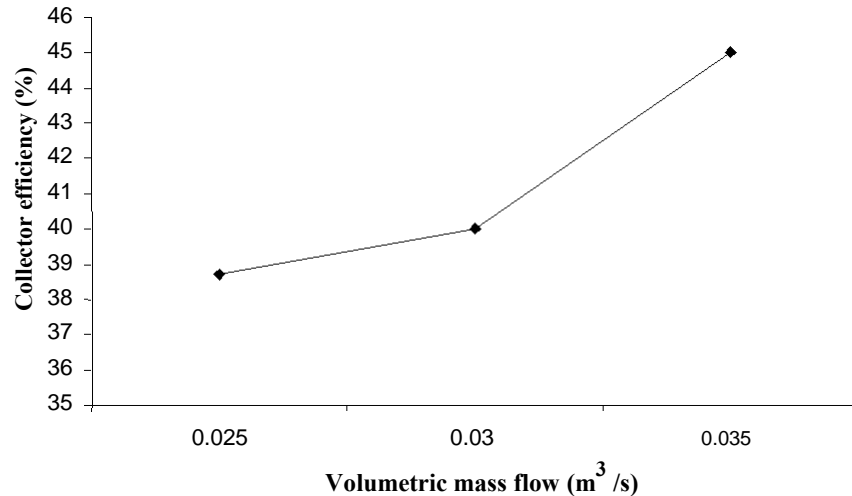

Figure 9. The daily collector efficiency versus volumetric air flow rate.

6. The more significant factor for drying is the temperature difference between the output and input temperatures.

Nomenclature: **A**, Area m²; **Ac**, collector area m²; **Aduct**, Duct area m²; **Re**, Reynolds number; **T**, temperature (°C); **To**, temperature air outlet of collector (°C); **Ti**, temperature air inlet of Collector (°C); **Ta**, temperature ambient (°C); **Tp**, temperature absorbing plate; **CP**, specific heat (kJ/kg°C); **Dh**, hydraulic diameter (m); **F**, coefficient of collector efficiency; **FR**, heat removal factor of collector; **G**, ratio of the collector mass flow rate to collector area (kg/s.m²); **Hc**, forced convection heat transfer coefficient (W/m²°C); **hw**, convection coefficient for the air between the top glass cover and environment; **WI**, initial moisture content; **WF**, final moisture content; **Π**, incident solar radiation (W/m²); **K**, conduction heat transfer coefficient (W/m. °C); **U**, heat loss coefficient (W/m² °C); **L**, distance between glass cover and absorber (m); **Mw**, initial mass of the crop (kg) *m*, the air flow rate (kg/s); **ma**, weight of air circulated kg. **mw**, weight of water evaporated kg. **N**, number of glass covers; **Nu**, Nusselt number; **Pr**, Prandtl number; **Qu**, useful energy gain W; **QR**, amount of heat required; \bar{v} , wind speed (m/s).

Greek symbols: α , Absorptance of the absorbing plate; α' , collector effective absorptance; β , tilt angle of collector measured from horizontal; ε , emissivity; η , efficiency; μ , air viscosity (kg/m.s); σ , Stefan – Boltzman constant (W/m².k⁴); τ , transmissivity of glass cover; ϕ , angle of corrugated absorbing plate (degree).

REFERENCES

- ANSI /ASAE S423 DEC 1991(R2007). Thermal performance testing of Solar Ambient Air Heaters. The American Society of Heating, Refrigerating, and Air-Conditioning Engineers.
- Akinola AO (1999). Development and Performance Evaluation of a Mixed-Mode Solar Food Dryer. M. Eng. Thesis, Federal University of Technology, Akure, Nigeria.
- Akinola AO, Apetu OP (2006). Exergetic Analysis of a Mixed-Mode Solar Dryer. J. Engin. Appl. Sci., 1: 205-210.
- Akinola OA, Akinyemi AA, Bolaji BO (2006). Evaluation of traditional and solar fish drying systems towards enhancing fish storage and preservation in Nigeria. J. Fish. Int. Pakistan, 1(3-4): 44-49.
- Ertekin C, Yaldiz O (2004). Drying of eggplant and selection of a suitable thin layer drying model, J. Food Eng., 63: 349-359.
- EKurtbas I, Turgut E (2006). Experimental investigation of solar air heater with free and fixed fins: efficiency and energy loss. Int. J. Sci. Technol., 1(1): 75-82.
- Ikejiofor ID (1985). Passive solar cabinet dryer for drying agricultural products. In: O. Awe (Editor), African Union of Physics. Proc. Workshop Phys. Tech. Solar Energy Convers, Univ. of Ibadan, Nigeria, pp. 157-65.
- Garg HP, Datta G (1984): The top loss calculation for flat plate solar collector, Sol. Energy, pp. 1-32.
- Duffie JA, Beckman WA (1991). Solar engineering of thermal processes, John Wiley and Sons, New York.
- Jompob W (2006). A Mathematical Modeling Study of Hot Air Drying for Some Agricultural Products. Thammasaltn t. J. Sc. Tech., pp. 1- 11.