

Full Length Research Paper

Reforming the pension system in Romania with logical schemes

Carina-Elena Steg roiu¹ and Valentin Steg roiu^{2*}

¹Faculty of Economics and Business Administration, University Constantin Brâncu i", Targu Jiu, Romania.

²Faculty of Economics, University Titu Maiorescu" Bucharest, Targu Jiu, Romania.

Accepted 1 July, 2011

In the current economic context pension system in Romania is in a sharp crisis and the financial system both because our involvement decision makers in applying a balancing structural reforms - entry-exit-benefit. Starting from this, we tried through this study, a possible adjustment of public pension scheme using logical schemes through analysis of pension schemes, whose principles lead to a possible model that can be implemented in the security system Romanian social, which could lead to an economic imbalance, so necessary in the current juncture. Study findings lead to the need for the Romanian social security policy, taking into account the model developed with logical schemes.

Key words: Social security, public pension, labor market, social insurance.

INTRODUCTION

Pension problem, considered in the light of particularly acute demographic and financial situation, is one of the most current issues in focus and is seeking various forms of mitigation of their effects both in our country and globally.

With the average size of pensions provided by the state being about 60% of the subsistence minimum for the bulk of retirees, the need to ensure a decent living in the post-active is becoming increasingly obvious, and an inefficient public system and current pension becomes very acute. Over these considerations, the global economic crisis overlaps with particularly acute demographic crisis caused by the accelerated aging of the population in the context of low birth rates and the major phenomenon of the working population exodus abroad creates a strong pressure on public pension fund, which for a considerable time, no one has been able to provide a standard of living for the mass of pensioners.

Regulations were introduced with the entry into force of the law of pensions, pension reform were prepared and Romanian insurance legislation were put down to implement community regulations concerning the

application of social security systems of employees, independent workers and members of their families moving within the community and establishing procedures for their implementation (Regulation EEC nr. 1408/71, Regulation EEC nr. 574/72, Steg roiu, 2007a). The reform began with the adoption of the new pension law and has continued to adopt laws on compulsory component - Pillar II and with the optional - Pillar III (Steg roiu, 2007b).

State social insurance pensions are defined as entitlements granted to employees after a specified period of activity and age provided by law or if the total loss or most of the work capacity and survivors of such person (Steg roiu, 2002). This definition follows the main categories of social security pensions covered by the state: the pension for work and old age, invalidity pension, survivor's pension.

In this respect we can say that Romania urgently needs to harmonize the pension scheme for salaried workers, officials, independent workers, farmers and especially civil servants and the budget sector should introduce a single law for the granting of a uniform pension for all these categories regardless of the work they do (www.ec.europa.eu/employment_social/missoc). Today, there should be a thorough reformulation and objective calculation of benefits, which would lead to a stronger link between benefits and contributions, including a system to grant a "bonus" for financial and delayed early withdrawals and changes in

*Corresponding author. E-mail: v.stegaroiu@yahoo.com.

governmental system of indexation of pensions. The basis change retirement scheme in Romania is required to put the principle of gradual transition from the old reform to the reformed scheme. Recommendation of a single pension scheme is a difficult task. Pension depends on the social policies of governors, which may change some parts of the scheme.

The current state of the public pension system in Romania

The demographic situation in Romania, and in fact all over Europe, is characterized by the phenomenon of "aging population", as defined by the scale of G. Bojio-Garnier, which shows that if the share of population of those aged over 60 years and the total number of inhabitants is higher than the level of 12%, then there is the phenomenon of "aging population". Thus, in 2008, in Romania the total number of people older than 60 years was 19.3% (source Eurostat). However, the average EU-25 remains lower, around about 16.5% (source Eurostat). Additionally, its proximity to the retirement age of those born during the baby boom years after World War II, the low birthrate and continuous exodus of jobs overseas assets, are all prerequisites for increasing the rate of aging population to over 30% in 2050 (source Eurostat).

Currently Romania faces major challenges regarding the sustainability of public pension system, both short and long term. This is, on the one hand, on short-term recovery issues, and on the other hand, about the problems caused, *inter alia*, the relatively small number of contributors to the system in relation to the number of beneficiaries and low employment rate of 41.4% for older workers, there is a high rate of undeclared work (approximately 20-50% of total employment, according to the definitions used), with yet insufficient resources.

The current public pension system in Romania is, the first pillar, the majority, a type intergenerational redistributive PAYG (Pay as You Go). The first pillar is referred to as the private and voluntary binding administered privately, and they are hitting the road in May with enough time to mature. Thus, in the first pillar, as is known, the current pension payment occurs following the procedure of redistribution of current revenues collected by the state social insurance budget (BASS), which due to delays in implementation of reform leads to a system currently unfair, while it is still supported by a viable multipillar. Therefore, we identified several deficiencies in the substance of the public pension system:

Mismanagement of social security funds

The results of which began to occur with increasing pressure growing on public pension fund, by increasing the state social security budget deficit, proving, if proof

were needed, weak public pension to ensure a higher minimum income for most existing pensioners;

Organization of redistributive type of system in place funded

Such a cap type of organization and allocation of assets is unquestionably a self-destruction of the current public pension fund, because it does not involve investing in accumulated assets of social security budget in financial instruments with a higher yield of, at least, the inflation rate. First, it deprives the capital market an important source of cash to develop its direct results, and on the other hand, creates demands on the entire public pension system, which is unable to cover current pension amount of government spending and even the erosion of pension indexation coverage over time;

Inequity in calculating and determining the nature of pension benefits

Due to the emergence of pension benefits among the so-called "service pension", there has been knowingly breach of the central principle of pensions law, which was to increase pressure on public fund pension, manifested by strong growth in the pension budget deficit;

ANALYSIS OF PUBLIC PENSION SCHEMES IN THE EU

Existence of effective social protection system, resulting in social actions of all stakeholders (entrepreneurs, state employees, foundations, church, unions, etc.), helps ensure a minimum income to those in difficulty or in some cases of personal services, maintenance, healthcare, education, transport, etc.

In what follows, we examined and demonstrated the operation of four public pension schemes, which in our understanding could form the basis of Romanian reform of the public pension scheme, considering them to be the perfect present, and the public market for such products.

Therefore, we analyzed the four types of retirement: type 1 (Austria), type 2 (Belgian) type 3 (Swedish) and type 4 (English). Determining pension scheme can be algorithmized (Figure 1), where T - the year when the individual retires, P - pension, ST - payment for the month.

The next type of retirement proposed several possible alternatives for considering the determining pension policies in Romania is that of the Belgian (Figure 2). Government of Romania has made important steps in order to increase the adequacy of pensions, reforms are needed to direct reference to early retirement, to

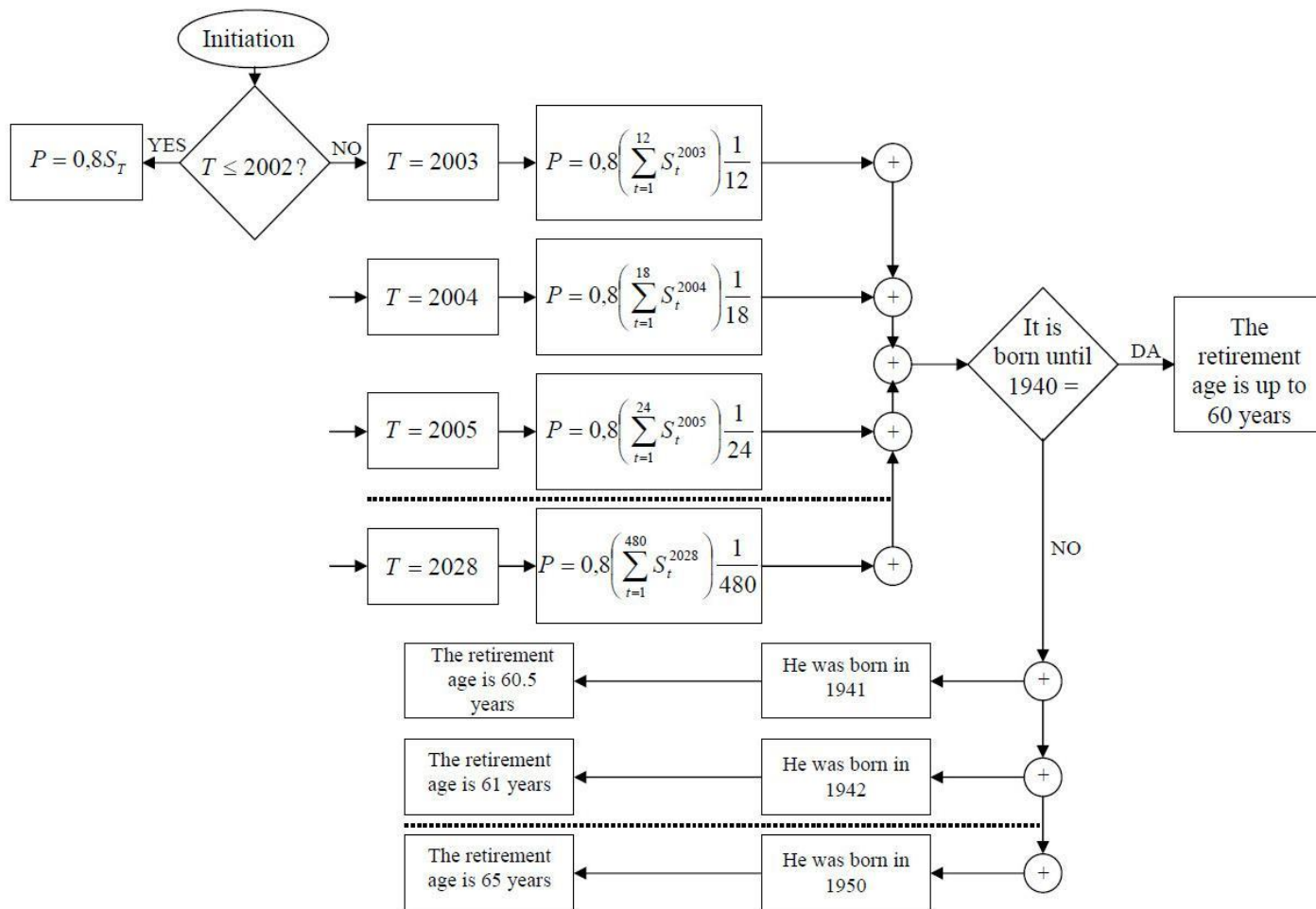

Figure 1. Scheme-block "Retirement type 1 (Austria)". Source: Elaborated by the authors.

encourage participation in working life of persons aged 50 to 60 years, thus achieving the so-called "pact between generations". This reform should make an important contribution within the meaning of acceptability and financial sustainability. In addition, promotion of occupational pension schemes could lead to increased long-term replacement rates and would also raise the standard of living of pensioners.

The process of establishing pension scheme such as 2 can be shaped in Figure 2. Where S_t^T - monthly salary in retirement; T - year retirement; θ - the entry into business. Along with these measures, confirmed increased participation in employment of persons aged 50 to 60 years to ensure financial sustainability strategy should continue to be based on comprehensive management of social security and the reallocation of contributions collected in this regard as well as debt reduction. Savings from debt reduction could be transferred to a reserve fund for future expenses and then redirected made segment of old age pensions.

A successful retirement scheme, in our view, has developed Sweden, which has managed to create a

public pension system that meets the criterion of adequacy and financial stability, given that compensated workers' scheduled replacement rates decreased by leaving the labor market much later. Sweden also provided financial sustainability of the pension system by expanding the reserve fund created in 1960 (it reached a value of 30% of GDP in 2005). Occupational pensions also made a notable contribution in circumstances in which cover approximately 90% of employees and usually provide an additional income amounting to approximately 10-15% of total salary of a worker (Ginsburg, 1992). Swedish pension system provides a comprehensive computerization, an example of annual achievement made up of a declaration of income accruing to that time and an estimate of the evolution of pension rights and sends them to its members. Although the actuarial neutrality of the system and flexible opportunities to withdraw from the labor market should be able to prevent early retirement, there are trends to develop ways to surrender early in the labor market, particularly through medical problems through benefits for disability (Whitehouse, 2007; European Commission, 2006).

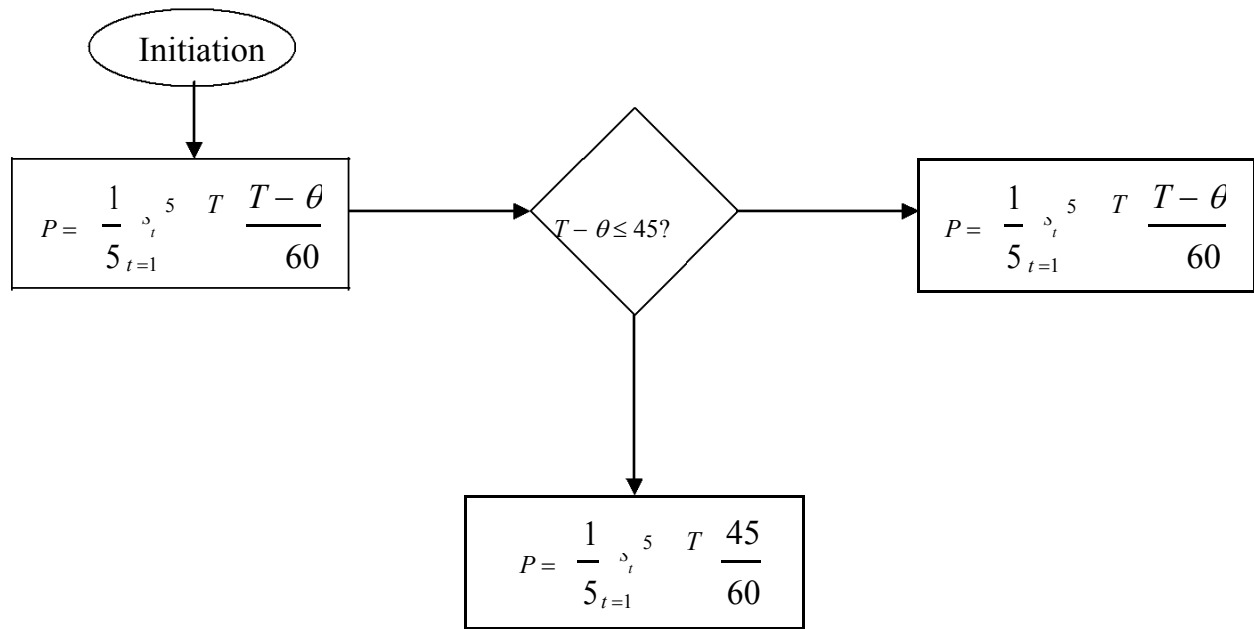

Figure 2. Scheme-block "Retirement type 2 (Belgian)". Source: Elaborated by the authors.

Scheme work in Swedish type has no rules relating to nationality or residence unless the pension rights for "child-raising years". There is no vesting period or terms of insurance of workers in Sweden. It matters only in pensionable income no matter whether the income is earned in a month or in 12 months. Pension rights are based on pensionable income. The pension system is coordinated with the tax system. According to the main rules, pension rights are calculated based on taxable income. The scheme is a defined contribution scheme funded by contributions from employers and employees and to some extent on overall taxable income. Employers' contributions are taxed as a charge on the total wages and are calculated as a percentage of taxable income from work. Contributions are collected by state and it is obliged to transfer 18.5% of pensionable income from the pension fund. The pension is calculated based on average lifetime earnings. There is no "maximum qualification" and any rules that have pension amount calculated according to gain income "best years". Both accrued pension rights and pensions are index linked to average earnings. A crucial thing is the aggregate value of pension rights when called upon retirement. No matter if those rights are won for 20 or 50 years (Olson, 1990). In our opinion the system is very flexible. There is no fixed retirement age in the scheme linked to earnings (but guaranteed pension is granted at 65 years regardless of sex). An insured person may apply for pension from the age of 61 years and may postpone it for an indefinite period. When it is required that pension affects the amount of pension according to actuarial principles. A person who continues to work after normal retirement age continues to acquire new pension rights. An applicant may choose

to eliminate a fraction of accrued pension rights by 1 / 4, 1 / 2, 3 / 4 of a pension. The person may also choose between the two components of the scheme (PAYG component prefinancing component) and to defer payment of the other component. An applicant may discontinue a pension payment when he gets another job. Swedish-type system can be modeled to that of Figure 3.

A special recognition from the generated company, which contributed to increased economic potential found in a retirement scheme in the UK, is shown in Figure 4.

Through reforms (European Commission, 1995) of recent state pension Secondary (PSS) and "pension credit" (PA), Britain has made progress towards pension adequacy. The rates of poverty of pensioners have fallen in recent years and is expected to decline further, given that HP will take effect fully. UK pension schemes are also characterized, for many workers, with significant contributions to the occupational and personal pension schemes, and this does not possibly involve a pension such as a type of PSS (but not the main scheme supported by state pensions).

Subsequently, the process adequacy and sustainability of pensions depends on the extension, more than in other countries, coverage and performance of private pensions. In this respect, at least three goals for the future are born fitness. The first is the impact of DC pension plans to transfer the contributions to occupational pension schemes (Turner, 2005). The second is the possibility of increasing the amount of insurance offered by the state basic pension increases through other sources of income for retirement. The third is how to continue the process of improving incentives for

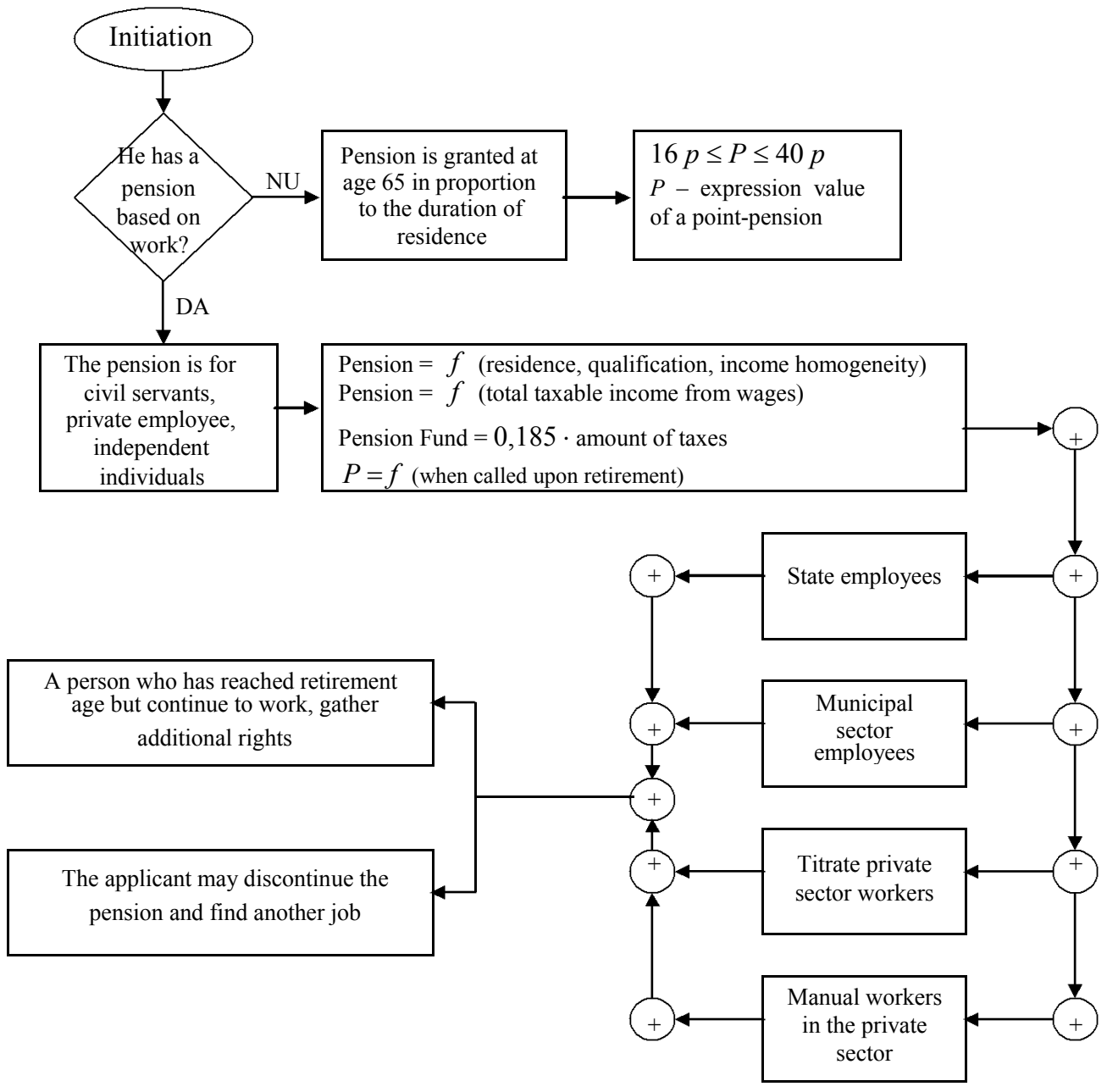

Figure 3. Scheme-block "Retirement type 3 (Swedish)". Source: Elaborated by the authors.

continuing work after a certain age and also for subsequent savings. English government established a Pensions Commission in 2002, which can monitor the adequacy of private pension savings and in particular to assess where there is a need to "move from a voluntary approach". In the second recent report published by the Pensions Commission, they made a number of proposals such as increasing the retirement age, redirection of income indexed to the state pension system and establishing a national pension savings scheme, with low cost and being centrally organized, in which workers have the opportunity to self-include (but

with the option to abandon). The UK Government has opened a new stage in the national pension's debate, with the intention to submit a list containing their proposals for pension reform in the spring of 2006 (Whitehouse, 2007, European Commission, 2006).

The UK pension system for civil servants includes several elements: Main scheme of civil service pensions (SPPSC), Compensation Scheme for Civil Service (SCSC), additional voluntary contributions scheme of Social Service (SCVSSS) and Scheme Benefits for the injuries of Social Service (SPVSS). All these elements are statutory scheme of the Act of 1972.

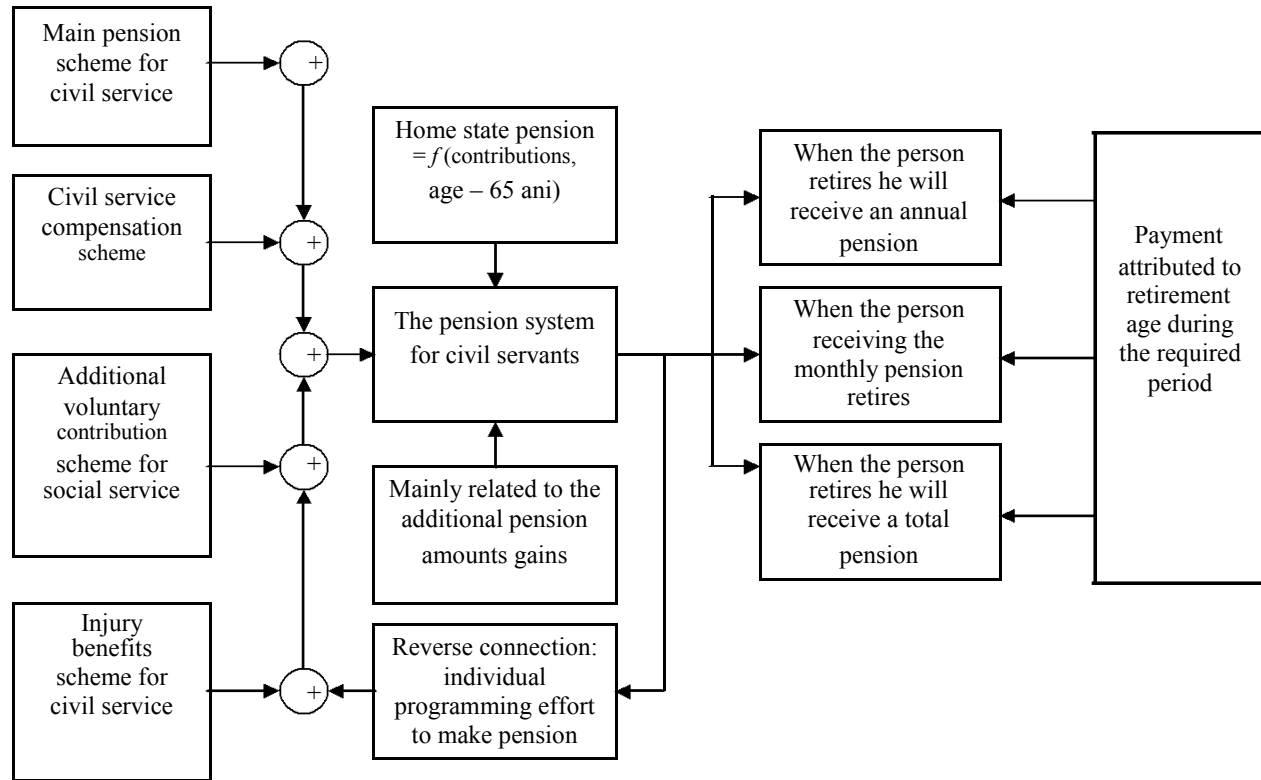

Figure 4. Scheme-block "Retirement type 4 (English)". Source: Elaborated by the authors.

SPPSC is occupational pension scheme for civil service providing retirement benefits. SCSC includes cases of early retirement and need. SCVSSS provide officials with additional contributions through a money purchase arrangement to provide a supplementary pension and benefits for life. SPVSS insures the income of civil servants who are injured or die during service. Membership in these schemes includes all civil servants (European Commission, 2007). In addition, state pension provides Main State (SLS), PSS and Guaranteed Income (VMG). PPS is given to those who have paid enough national insurance contributions during their working lives. It is paid from age 65 for men and 60 for women although women's retirement age will rise to 65 years between 2010-2020. PSS provides a basic pension and supplementary pension is linked to earnings. The rules for calculating the classical scheme is as follows: when a person retires, he will receive an annual pension and a lump sum. The amount of these benefits depends on the payment considered retirement age and duration required. Age part-time is taken into account based on hours worked and paid full-time retirement. However, in the past there were various restrictions on persons entitled to participate in the scheme based on hours worked.

The maximum retirement age should be 40 years. A person can accumulate seniority if they are working after retirement age but not more than 45 years. When the person is old enough to receive state pension, the

main pension is paid in addition to traditional pensions only if the person has paid the necessary contributions. The rules of calculation can be expressed by diagram block (Figure 4).

The amount of pension P_j , $j = 1, 2, 3, 4$ depends on social policy that can support one of the types discussed:

$$P_j = (j^3 - 6j^2 + 11 \cdot j - 6) \cdot 0,17P_4 - (j^3 - 7j^2 + 14 \cdot j - 8) \cdot 0,5P_3 + (j^3 - 8j^2 + 19 \cdot j - 12) \cdot 0,5P_2 + (j^3 - 9j^2 + 26 \cdot j - 24) \cdot 0,17P_1 \quad (1)$$

Calculation of pension schemes is carried out after 1, 2, 3, 4, social policy directs the amount of pension (Figure 5).

ANALYSIS OF PUBLIC PENSION SCHEMES IN ROMANIA

The public system of social security pension amount on retirement entry is determined by multiplying the annual average score achieved by the insured during the period of contribution to the value of a pension point of retirement months.

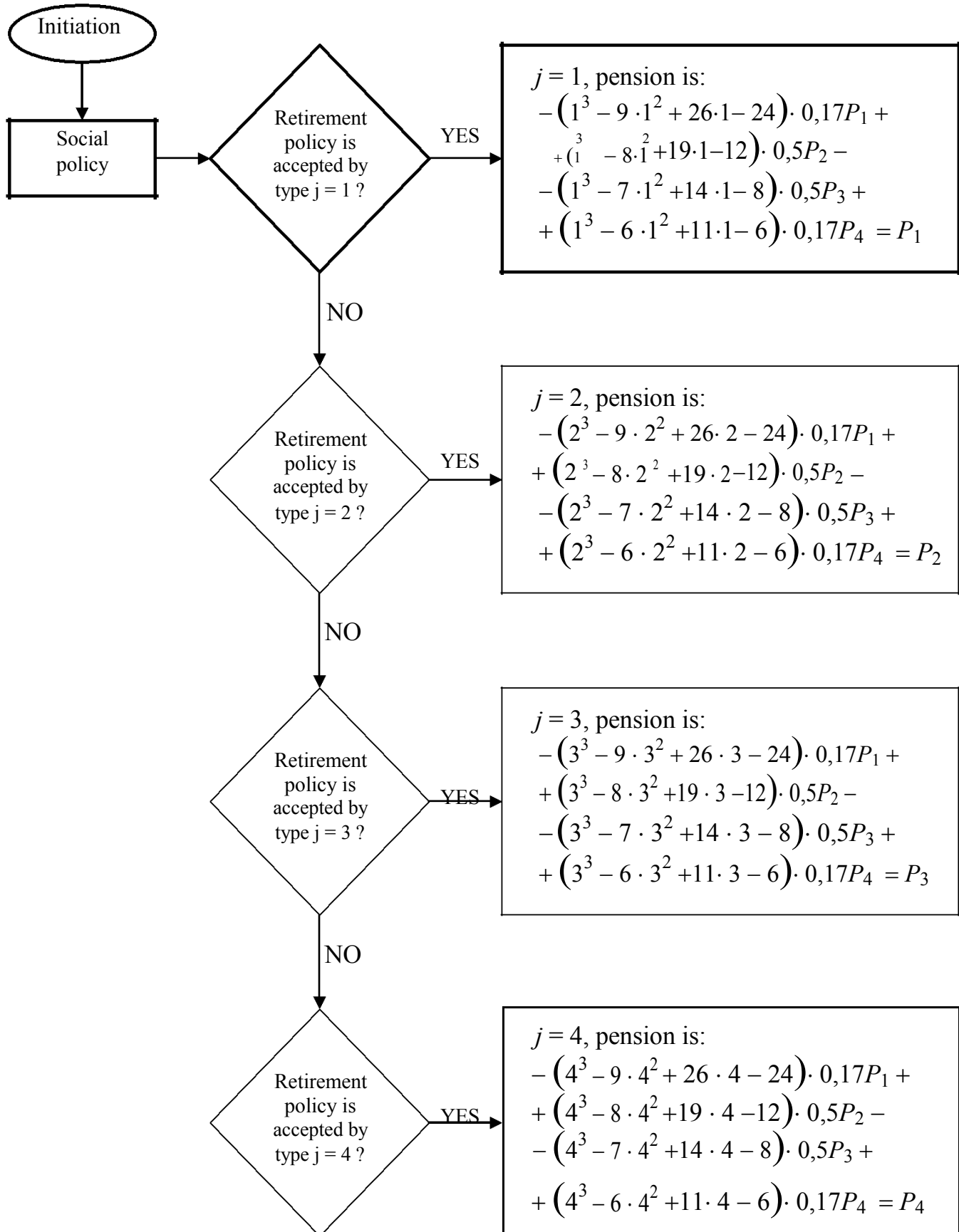

Figure 5. Scheme-block "pension depends on social policy". Source: Elaborated by the authors.

Table 1. Coefficients matrix-multiplying.

Elasticity access	E_1	E_2	...	E_j	...	E_β
A_1	γ_{11}	γ_{12}	...	γ_{1j}	...	$\gamma_{1\beta}$
A_2	γ_{21}	γ_{22}	...	γ_{2j}	...	$\gamma_{2\beta}$
A_i	γ_{i1}	γ_{i2}	...	γ_{ij}	...	$\gamma_{i\beta}$
A_α	$\gamma_{\alpha 1}$	$\gamma_{\alpha 2}$...	$\gamma_{\alpha j}$...	$\gamma_{\alpha \beta}$

Source: Elaborated by the authors.

Basically theoretical calculation of the pension formula can be (IER, 2004):

$$C_p = \frac{(Vba_i / Vbm_i)}{Sc} \cdot A \cdot E \cdot Vpp \quad (2)$$

Where:

C_p = Amount of pension.

Vba_i = Average gross income of the insured in "i".

i = Year in which the subject worked.

Vbm_i = Gross average income in the year "and" press CNS.

Sc = The complete contribution.

A = Coefficient of access (by type of pension like "survivor's pension, the level of disability, etc).

E = Coefficient of elasticity (0.3% weighting for additional months worked after retirement age so the additional 3.6% per year worked).

Vpp = Value of the pension point.

For a comprehensive treatment of the pension system in Romania, one starts to analyze the amount of pension that depends on a number of factors: the average income of the insured in each year, which for reasons known from year to year changes, the average income of an individual insured at the economy, the number of years of contribution to the required stage, the type of activity, for certain favors called elasticity, the level of economic development at the time of retirement. An original treatment of the problem of calculating the pension is found in IER 2004. Developing the formula as it was originally treated, we note by x_t , \bar{x}_t - average income of the insured, an insured in the national economy (or in the branch considered), $t = 1, 2, \dots, T$, where T - number of years needed to achieve the complete contribution. The report

$\frac{x_t}{\bar{x}_t}$ obtains the share of income than the average

insured in the economy in $t, t = 1, 2, \dots, T$. To make different in different years, this report will be different and is less than or greater than 1. We call these

"parties" points. During $(0, T)$ policy holder will accumulate a total of $\frac{x_1}{x_1} + \frac{x_2}{x_2} + \dots + \frac{x_t}{x_t} + \dots + \frac{x_T}{x_T} = \frac{x}{x_t}$ points, the arithmetic mean is:

$$\frac{1}{T} \sum_{t=1}^T \frac{x}{x_t} \text{points} \quad (3)$$

Access to retirement is a vector (\bar{A}) . Policy holder may be entitled to a pension as the survivor, the level of disability, etc. Mean $A = (A_1, A_2, \dots, A_i, \dots, A_\alpha)$. Depending on the specific work of importance to society, their being put on the insured, etc., pension may be increased under a law (elasticity pension). And elasticity of the pension is thus vector

$E = (E_1, E_2, \dots, E_j, \dots, E_\beta)$. To include all possible options in terms of "access to retirement", "elasticity pension" elaborates matrix of coefficients multiplying

$\gamma_{ij} = A_i \cdot E_j, i = 1, 2, \dots, \alpha, j = 1, 2, \dots, \beta$ (Table 1).

So policy holders through coefficients $\gamma_{ij}, i = 1, 2, \dots, \alpha, j = 1, 2, \dots, \beta$ will be disadvantaged by the number of points accumulated during the interval to ensure $(0; T)$. Pension points can be expressed:

$$P_{ij} = \frac{\gamma_{ij}}{T} \sum_{t=1}^T \frac{x}{x_t} \text{points} \quad (4)$$

A point expressed value in retirement year is estimated at $V \frac{lei}{\text{point}}$. So pension expressed in RON is to be:

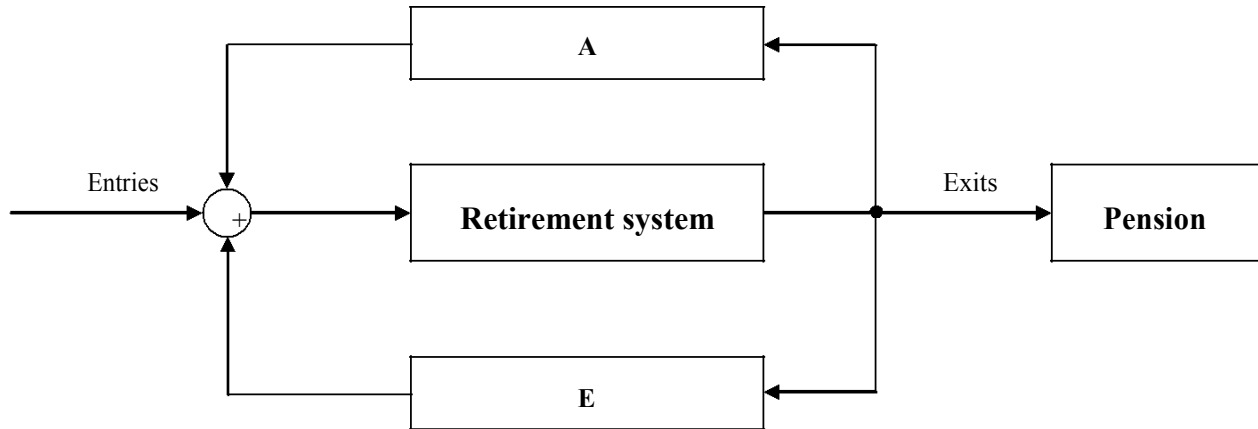

Figure 6. Block diagram A – E. Source: Elaborated by the authors.

$$r_{ij} = \frac{\gamma_{ij} \cdot V}{T_{t=1}} \quad \frac{T}{x_t} \text{ RON} \quad (5)$$

Establishing a pension in this way has a number of reasons: it takes into account the whole range of activity of the insured, the insured income, and average incomes in the national economy each year, in a way that the country's economic crisis periods, inflation years of crisis affecting the interests of future pensioners, ensure a certain social equity by establishing a single value of a pension point. Part low: coefficients γ_{ij} , $i = 1, 2, \dots, \alpha$; $j = 1, 2, \dots, \beta$, are constant in time. In our view, multiplying factors and the expression value of pension points must evolve over time, and should be replaced with:

$$\gamma_{ij}^{(t)}, \quad i = 1, 2, \dots, \alpha; \quad j = 1, 2, \dots, \beta; \quad t = 1, 2, \dots, T$$

Coefficients "access" (A) and "Elasticity" (E) can also be used by authorities as a "rules-stimulant" (Figure 6). As a "regular" retirement system, called the system tuned serve, governments set the value $V^{(t)}$ as a point of pension for policyholders with vectors A and E. Pension can be expressed in calculated value using the formula:

$$P_{ij}^{(t)} = \frac{\gamma_{ij}^{(t)} \cdot V^{(t)}}{T} \cdot tgQ_t \quad (6)$$

Where angle Q_t is the slope function $x_t = f(\bar{x}_t)$ (Figure 7).

$$\frac{x_t}{x_t} = P - \text{points made by the insured in } t. \quad x_t = P \cdot x_t$$

Increase or decrease on the angle Q_t depends on the effort of a policyholder to earn more (Δx_t), government authorities may, if they allow their economic development, increase expression of the pension point value, the insured's effort for the benefit of the coefficient A to increase the angle Q_t with $\Delta Q^{(A)}$, coefficient E to increase $\Delta Q^{(E)}$, the national economic development through the media \bar{x}_t may have an increase of $\Delta \bar{x}_t$. Increasing the pension point value is a consequence of GDP growth, and hence the average growth x_t . Consequently, the pension may increase, remain constant or even reduce (Figure 8).

As such, full length public pension is calculated for the entire contributory period according to three basic components: gross monthly salary of the insurers which formed the basis for calculating the individual contribution of social security; achieved gross average wage in the economy of each month contributory period; and a pension point value is set annually by law approving the budget of social security as a percentage between 30 and 50% of the gross average salary used to substantiate the state social insurance budget.

CONCLUSIONS

Romania, based on economic and societal factors must prepare its retirement schemes. Schemes of type 1, 2, 3, 4, have been earlier stated on the basis of these elaborations. The current system of retirement in our country has not been adequate in combating economic and social problems. According to our calculations, 27% of the active work force has emigrated from Romania. Method of determining pension in Romania along with some priorities (excluding the impact of inflation), has not always been reflected on the applicant during his active contribution. Pension is determined by the

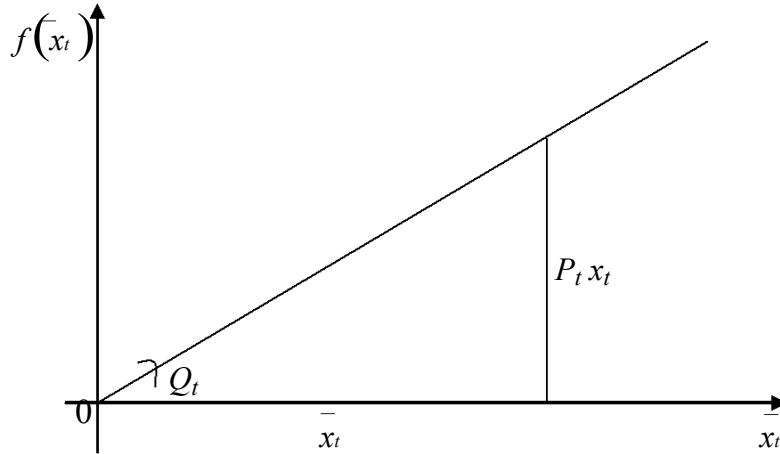

Figure 7. Graphic interpretation of the points in t. Source: Elaborated by the authors.

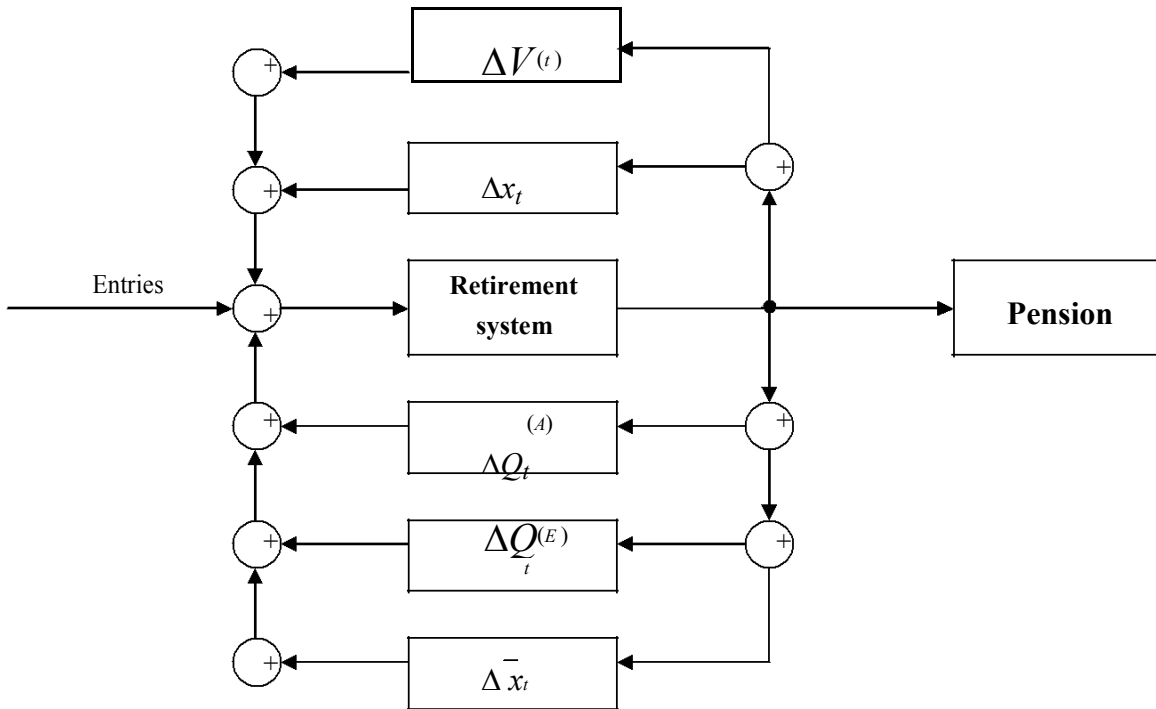

Figure 8. Adjustment system "Pension". Source: Elaborated by the authors.

formula:

$$P_{ij} = \frac{\gamma_{ij} V_T X}{T \sum_{t=1}^t \bar{X}_t} \quad (7)$$

The national economy of some categories of specialists' salary increases under the impact of external factors (For example, workers in the banking, insurance of goods etc). In this case, the amount of reported $\frac{X_t}{\bar{X}_t}$ is

reduced: some experts in the economy will be unduly disadvantaged when they apply for grant of pension (due to increased average value \bar{X}).

Another issue is that an individual specializes in an area during 2/3 of his active life and only 1/3 is used for creative purposes. This asks for a review of the active period of employment, the age limit should in our view, be flexible. In our opinion, we believe that an individual may receive any age pension, pension for the time being active, the contribution paid. Figure 9

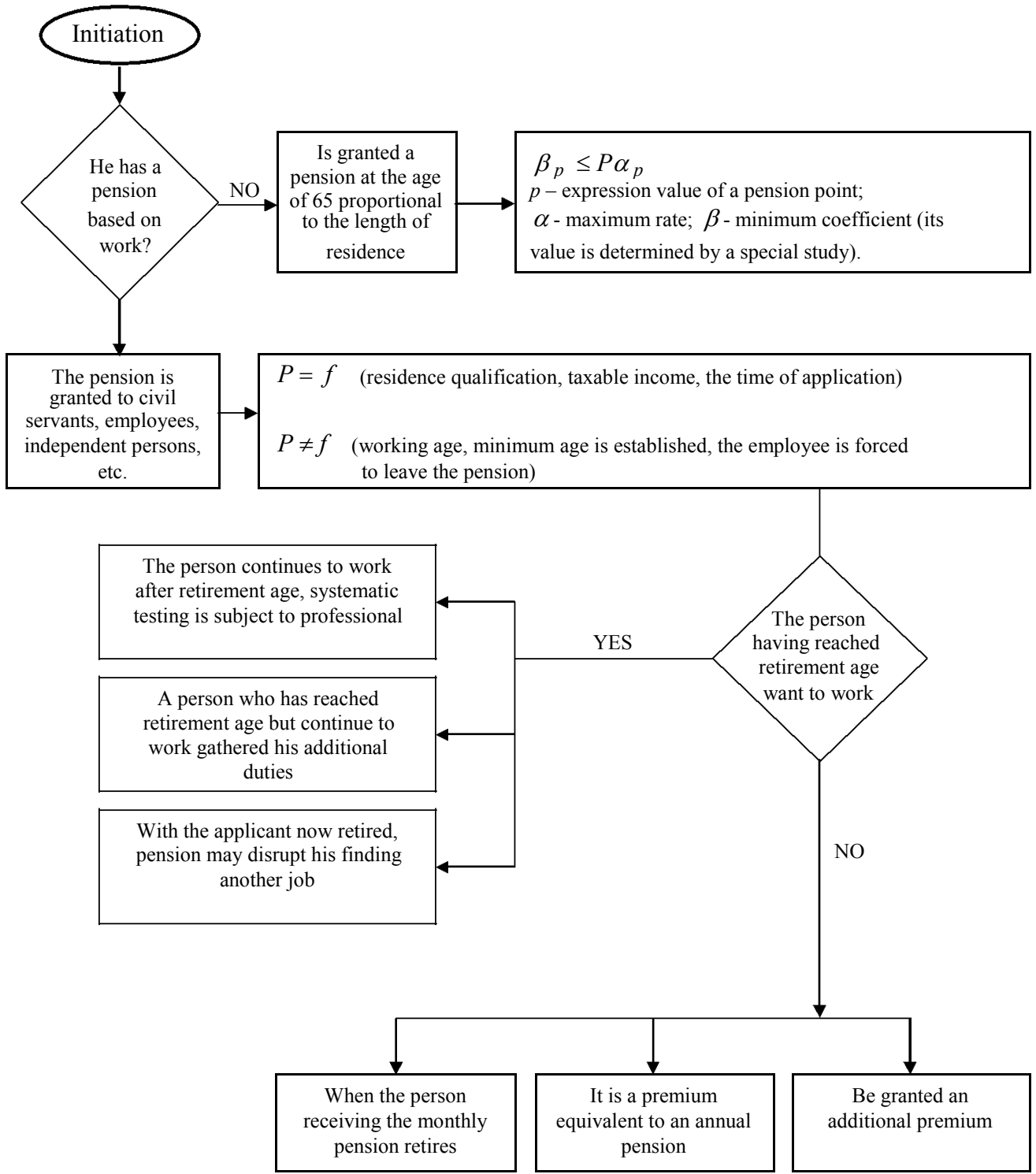

Figure 9. Scheme-block "Romanian pension system type". Source: Elaborated by the authors.

algorithmized.

Insurance schemes across from major structural changes are characterized by a multitude of principles that differ according to the difficulties covered by the evolution of society as a whole. A number of major trends appear to be aimed at studying various problems

facing social security and pension schemes. Social security protection of the unemployed and not the least of the whole system of financing social protection efforts of most European countries differ from one state to another. Countries that have fully reformed insurance system have radical social change leading to the basic

pension schemes. Also countries that have statutory schemes further have institutional reform, and have begun to reform themselves to social security pension, while countries that are at the stage of negotiations and research with social partners look for a common point in starting the reform process.

The basic principle of the reform of social security systems is to reduce pressure on state intervention and this has direct consequences in increasing the efficiency of European social policies.

Redistributive pension reform takes place in order to find new methods and programs that promote the maintenance of the working life of persons in stalemate and the people who are partially incapacitated for work. Long-term evolution of demographic indicators will have a number of negative effects not only on revenue and expenditure of public pension insurance, but also on other public social expenditure, such as labor market itself with indirect implications on capital market. The principle governing the redistributive pension systems, which make a group active in the labor market, is decreasing steadily while that of the group of people withdrawn from the labor market is still growing.

REFERENCES

- Europa MISSOC – L'organisation de la protection sociale organigrammes et descriptions, www.ec.europa.eu/employment_social/missoc, pp. 60-61.
- European Commission (1995). The European Employment Strategy: Recent Progress and Prospects for the Future. Communication from the Commission on Trends and Developments in Employment Systems in the European Union. COM (95) 465 final, 11.10: 46.
- European Commission (2007). The EU in the world The foreign policy of the European Union, Directorate-General for Communication Publications, Brussels, p. 18.
- European Commission (2006). Adequate and sustainable pensions. Synthesis report, pp. 253-255, 256-260.
- European Institute of Romania (IER) (2004). Pension insurance system in Romania during transition: major problems and solutions, Bucharest, p. 33.
- Ginsburg N (1992). Divisions of Welfare: A Critical Introduction to Comparative Social Policy, London, Sage, pp. 30-33.
- Olson M (1990). How Bright Are the Northern Lights?: Some Questions about Sweden, Institute of Economic Research, Lund University, p. 43.
- Regulation (EEC) no. 1408/71 of 14 July (1971). on the application of social security schemes to employed persons and members of their families moving within the Community, published in Official Gazette no. L 149 of July 5, 1971.
- Regulation (EEC) no. 574/72 of 21 March (1972). Laying down detailed rules for implementing Regulation (EEC) no. 1408/71 on the application of social security schemes to employed persons and members of their families moving within the Community, published in Official Gazette no. L 74 of March 27, 1972.
- Steg roiu V (2002). Pension reform in Romania, Journal "Scientia" - review of studies, research and documentation, 3: 90-91.
- Steg roiu V (2007a). Social security reform in Romania, the scientific journal "Economic Studies", an. 1, no. 1-2, ULIM, Chisinau, pp. 239-244.
- Steg roiu V (2007b). Social security reform in Romania, the scientific journal "Law, Economics and Computer Science, Editura ASEM, Chisinau, 3 (13): 31-33.
- Turner JA (2005). Individual Accounts for Social Security Reform: International Perspective on the U.S. Debate, W. E. Ujohn Institute, p. 9.
- Whitehouse E (2007). Pensions Panorama, Retirement-Income Systems in 53 Countries, The World Bank, Washington D.C. pp. 113-115, 119-121.